

UNIT 0 WELCOME!

LESSON 1

1  1.1 LISTEN AND LOOK AT THE PICTURES.



1 FIND THE WAY AND TRACE THE WORDS.

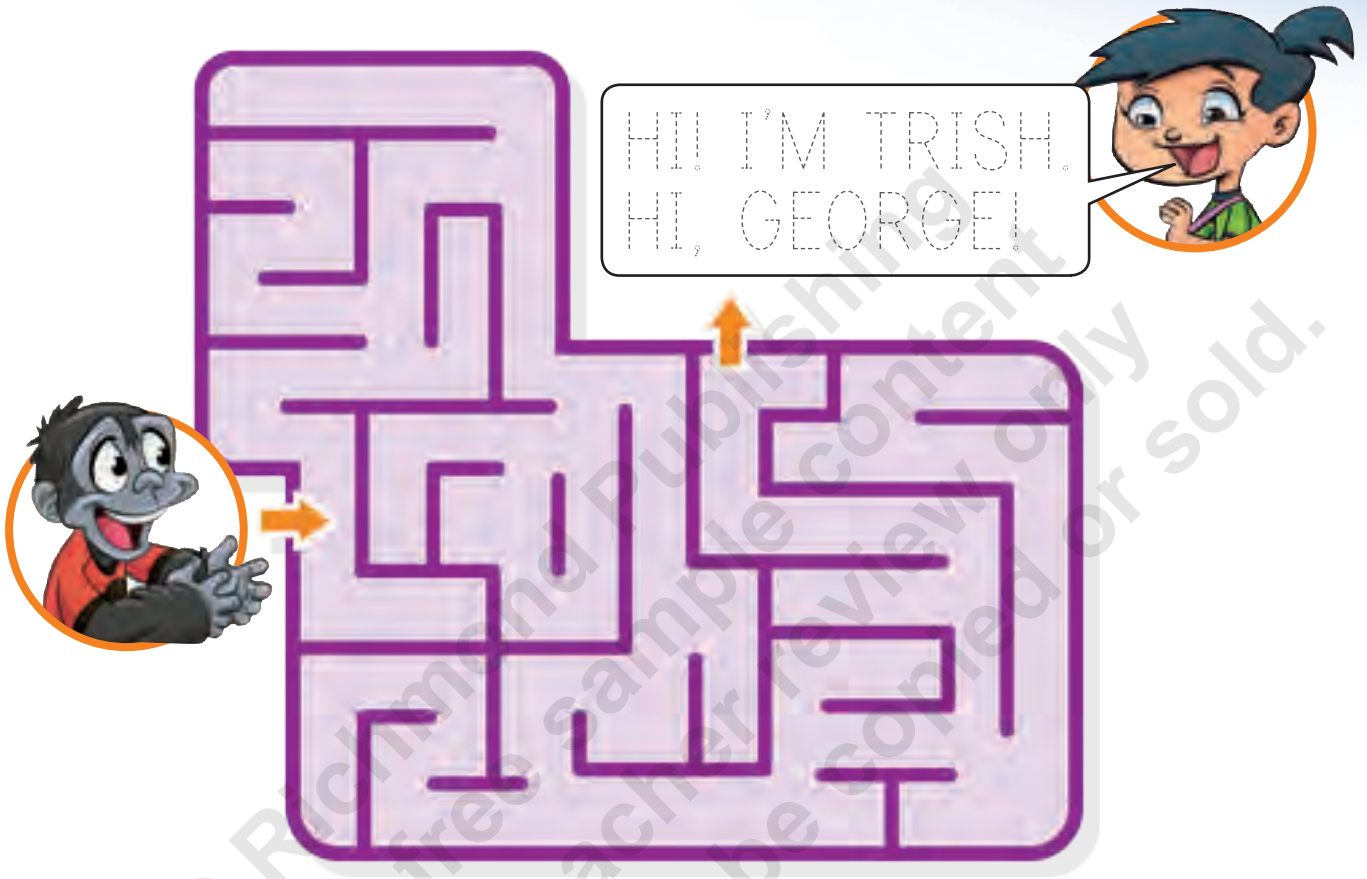

2 DRAW YOURSELF AND COMPLETE.



UNIT 1

HELLO!

LESSON 1

1  1.2 LISTEN AND LOOK AT THE PICTURES.



2  1.3 LISTEN AND REPEAT.

3 TRACE THE WORDS.



BOOK



RULER



PEN



PENCIL



SHARPENER



RUBBER

1  1.4 LISTEN AND CIRCLE THE SCHOOL OBJECTS.

WHAT'S THIS?

1



2



2  1.5 READ, LISTEN AND COLOUR.

WHAT COLOUR IS IT?

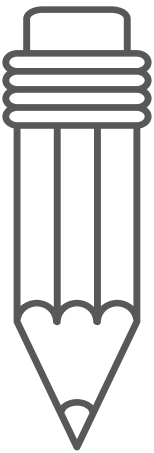

GREEN



BLUE



ORANGE



BLACK

GRAMMAR

WHAT'S THIS?
IT'S A BOOK.

GRAMMAR

WHAT COLOUR
IS IT? IT'S BLACK.

3  1.6 LISTEN AND CHANT.

WHAT'S THIS? WHAT COLOUR
IS IT? TELL ME, PLEASE.

IT'S A BOOK!
IT'S BLUE!
YIPEE!

4 SAY THE CHANT WITH
THESE OBJECTS.



1 POINT, SAY AND STICK.



2 POINT, ASK AND ANSWER.



1  1.7 LISTEN, REPEAT AND TRACE.

1  ONE

2  TWO

3  THREE

4  FOUR

5  FIVE

6  SIX

2 READ AND MATCH.

HOW MANY?

1. FOUR RULERS
2. TWO BOOKS
3. ONE SHARPENER



GRAMMAR

HOW MANY PENCILS? FIVE.

3 CUT OUT, ASK AND ANSWER.

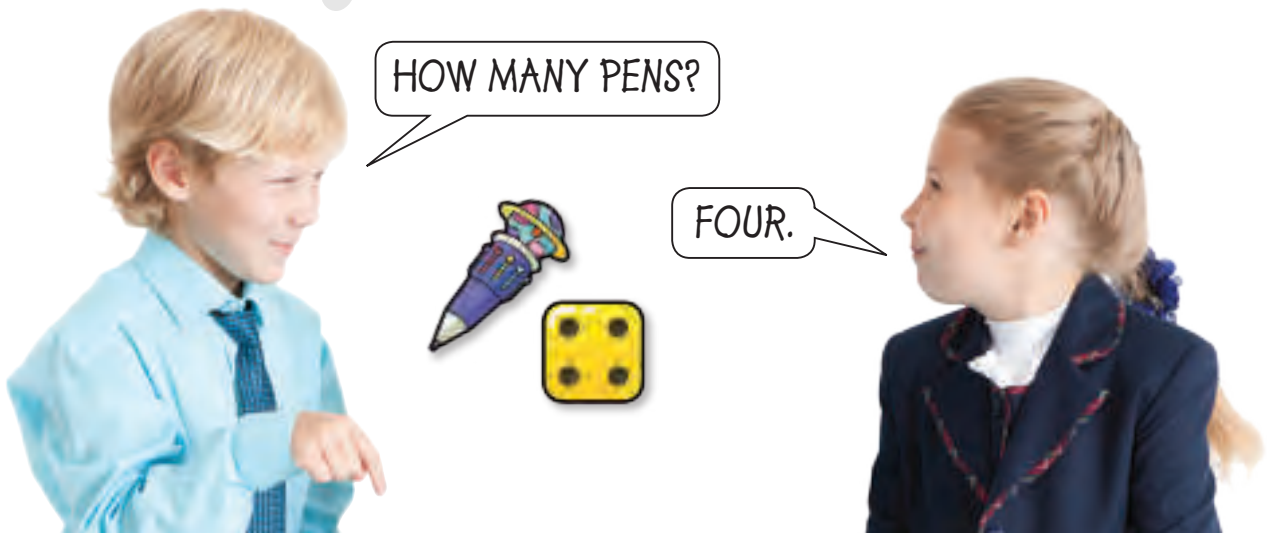

ANNIE AT SCHOOL



1  1.8 LISTEN AND LOOK AT THE PICTURES.

2 MATCH.

1. HOW ARE YOU?

2. WHAT'S THIS?

3. HOW MANY COLOURS?

IT'S A PEN.

I'M FINE, THANKS.

FOUR.

3 ACT OUT THE STORY.

PHONICS

1  1.9 LISTEN, TRACE AND POINT. REPEAT.

1.



APPLE



ANNIE



2.



BOOK



BLUE

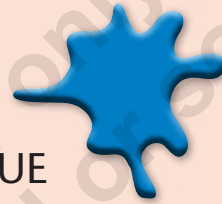

3.



CAT



COLOURS



4.



DAISY



DOG



2 LOOK AND CIRCLE.

1.



A B C D

2.



A B C D

3.



A B C D

4.



A B C D



1 LOOK AND TRACE.



RED



YELLOW



BLUE



YELLOW



BLUE



RED



ORANGE



GREEN



PURPLE

2 MAKE A PENCIL HOLDER.

1



2



3



4



IT'S RED,
YELLOW, BLUE...

GREETINGS

1  1.10 LISTEN AND CHANT.

GOOD MORNING TO YOU!

GOOD MORNING, ANNIE! GOOD MORNING TO YOU!
HELLO, MISS WATERS! HOW ARE YOU?
I'M FINE, THANKS. I'M FINE, THANKS!
GOOD MORNING! GOOD MORNING TO YOU!



2  1.11 LISTEN, READ AND MATCH.



HELLO!

GOOD MORNING!

HI!

GOODBYE!

BYE!

3 ACT OUT THE DIALOGUE.

HI! HOW ARE YOU?

HELLO! I'M FINE,
THANKS. AND YOU?

FINE, THANKS. GOODBYE!

BYE!

UNIT 1 REVIEW

1  1.12 LISTEN AND TICK (✓). THEN LISTEN AND SING.

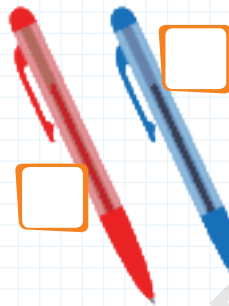
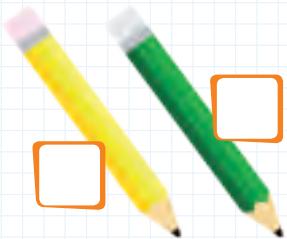

THE SCHOOL OBJECTS CHANT

WHAT'S THIS?

LET ME SEE! IT'S A ...

WHAT COLOUR IS IT? IT'S...

LET'S SHARE IT!

2 MATCH.

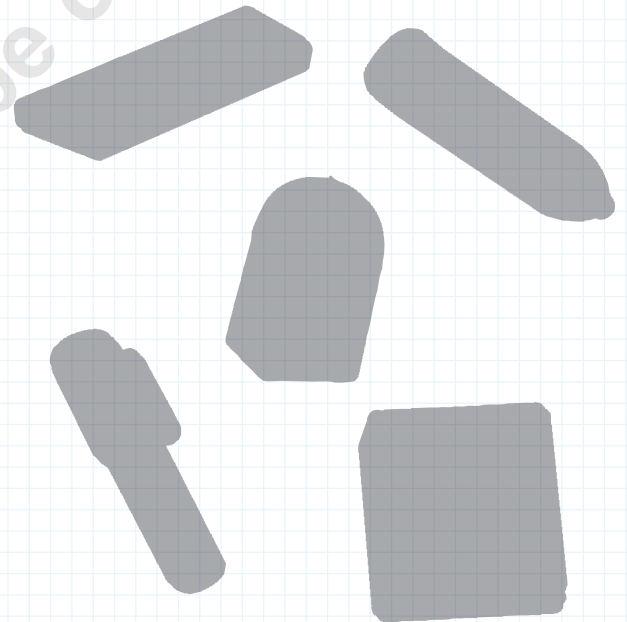

3 POINT, ASK AND ANSWER.

WHAT'S THIS?

IT'S A RULER.

UNIT 1 REVIEW

4 READ AND COLOUR.

HOW MANY...?



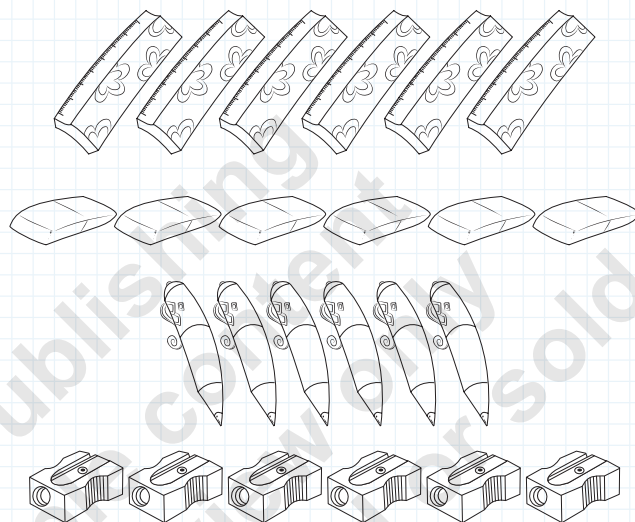

1. TWO RULERS.
2. ONE RUBBER.
3. FIVE PENS.
4. THREE SHARPENERS.

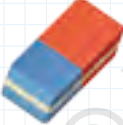

5 LOOK AND COMPLETE.

WHAT COLOUR IS IT?

~~BLUE~~ RED GREEN BLUE YELLOW

1.  IT'S B L U E AND _____
2.  IT'S _____
3.  IT'S _____
4.  IT'S _____

6 DRAW YOUR SCHOOL OBJECTS AND COLOUR THEM.

